

# Ultralift E Magnetic Lifter

The New Cost-Effective Choice for High Performance Lifting

Our brand new Ultralift E Magnetic Lifter range utilizes the latest in magnetic technology to provide a cost-effective lifting solution. The technology is fail-safe, extremely easy to operate, with no electricity required delivering world class results when handling ferrous loads compared to traditional methods such as slings, chains, hooks and grabs.



## Typical Applications

Our Ultralift E Magnetic Lifter range is ideal for applications ranging from light pick and place equipment to heavy steel stock movement.

This high performance Magnetic Lifter has been designed with safety uppermost in mind, in addition to utilizing permanent magnetic technology to ensure the load cannot be released during lifting. A secondary handle locking device provides further re-assurance that the load cannot be accidentally released when in use.



## Pricing

Part Number NA	Part Number UK	Description	CAD Price List
ULE0220	ULE0100	Ultralift E Lifting Magnet 220lbs	\$ 316.80
ULE0660	ULE0300	Ultralift E Lifting Magnet 660lbs	\$ 594.00
ULE1320	ULE0600	Ultralift E Lifting Magnet 1320lbs	\$ 999.90
ULE2200	ULE1000	Ultralift E Lifting Magnet 2200lbs	\$ 1,712.70
ULE4400	ULE2000	Ultralift E Lifting Magnet 4400lbs	\$ 2,242.35

# Technical Applications

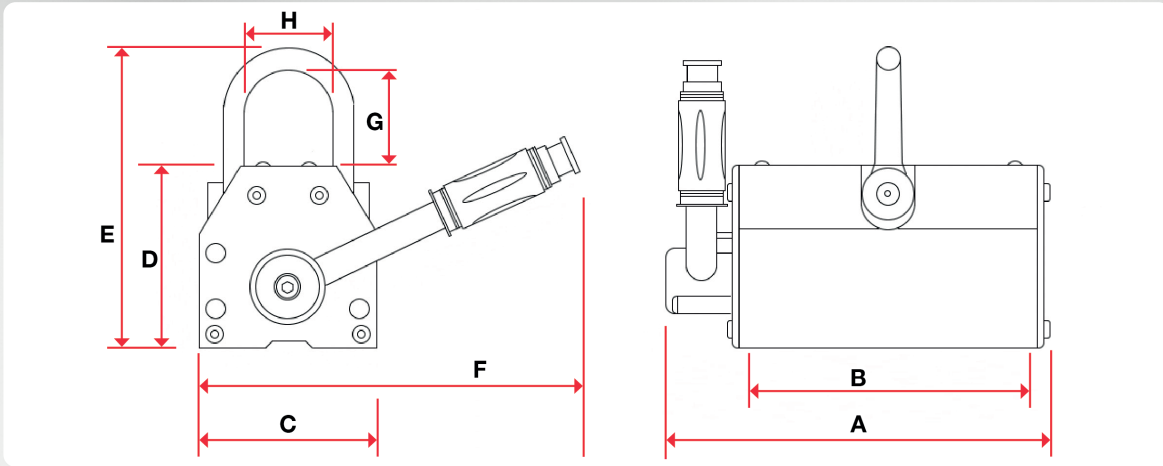

Part Number NA	Part Number UK	Dimensions (in)								Self Weight lb	Flat Section			Round Section		Units Per Pack
		A	B	C	D	E	F	G	H		WLL*	Thickness Min. in	Length Max. in	WLL* lb	Diameter Max. in	
ULE0220	ULE0100	5.2	3.6	2.6	3.0	4.9	7.3	1.8	1.3	6.7	220	0.6	39.3	110	3.1	1
ULE0660	ULE0300	8.0	6.2	3.7	3.7	6.7	10.0	2.5	1.8	22.1	660	0.8	59.0	330	3.9	1
ULE1320	ULE0600	11.1	9.8	4.7	4.6	8.7	11.0	3.5	2.4	50.7	1320	1.2	78.7	660	5.5	1
ULE2200	ULE1000	13.8	12.1	5.4	5.5	10.6	12.2	4.3	3.1	86.0	2200	1.6	98.4	1100	7.0	1
ULE4400**	ULE2000**	19.0	15.7	7.3	5.2	12.2	20.7	6.7	3.7	173.8	4400	2.2	120.0	1760	24.0	1

\* Please note that the Working Load Limit (WLL) is now used instead of Safe Working Load (SWL). The Lifting force values shown include the 3:1 safety factor and have been based on using thick high magnetic permeability steel with no air gaps. Air gaps, thinner materials and materials with lower magnetic permeability can all reduce the pull force a lifter can actually achieve. Please note that the achievable pull force is reduced when lifting thinner mild steel plate. Please note that the diameter of the round bar can affect the amount of lift that can be achieved. You must follow LOLER, PUWER, ASME B30.20 and H&S advice. You should always check for a downrate, factor in any downrate to then perform a safety lift, then perform a full lift only after a successful safety lift.

\*\* Measurements of this size of lifter to be confirmed.

## Performance

WWL performance criteria Flat ground mild steel plate of thickness, equal to or greater than the specified minimum thickness.  
3:1 safety factor compared to stated WLL

Temperature -10°C (14°F) / 40°C (104°F)

Humidity Tolerance 80%

## Materials

Magnet Material Rare earth neodymium iron boron (NdFeB)

End plates Aluminium - painted

Housing Mild steel

Pole feet Mild steel

## Conformity

The Supply of Machinery (Safety) Regulations 2008  
The Electrical Equipment (Safety) Regulations 2016  
The Electromagnetic Compatibility Regulations 2016  
LOLER Regulations 1998

Designated standards: EN ISO 12100:2010, EN 13854:2019, EN 13155:2020

If you have any questions, require technical assistance and would like a quotation, contact us at [sales@eclipsetoolsinc.com](mailto:sales@eclipsetoolsinc.com).

